



**RED SEAL
MEASUREMENT**

M-287
Rev. H
12/11/18

PL100

Pump for LPG Dispensers

Operation and Maintenance Manual



Table of Contents

Principle of Operation	3
PL100 Features	3
Motor Features	3
Installing the PL100	4
Inlet Piping Requirements:	4
Outlet Piping Requirements:	4
Bypass System Requirements:	4
Motor Installation	5
Operation of Your PL100 Pump	6
Filling New Cylinders and Tanks	6
Preventative Maintenance	6
Repair Service	6
Extended Storage Procedures	6
Seal Replacement Instructions	7
Parts Detail	10
Specifications	11
Performance	11
Dimensions	11
Troubleshooting Guide	12

Principle of Operation

The PL100 Pump is a regenerative turbine pump. Liquid is drawn into the inlet and enters a chamber where it flows around a double-sided impeller. The liquid entering the pump is directed into the vanes, which move the liquid forward while at the same time imparting a circulatory motion within the vane (figure 1a), increasing the liquid's kinetic energy. As the liquid leaves one vane, it is directed into the next, and the process is repeated (figure 1b). Each successive trip through the vanes results in a further gain of energy. This process is called regeneration, and enables the pump to deliver an outlet pressure up to ten times greater than a centrifugal pump with the same impeller diameter.

As the differential pressure (between the inlet and outlet) increases, the horsepower required to drive the pump increases, and the capacity decreases.

Since the impeller is the only moving part and has no contact with the casing, it experiences practically no wear, even when pumping volatile, non-lubricating liquids such as LP gas.

PL100 Features

The PL100 has been specifically designed and manufactured to meet the rigorous requirements for pumping volatile liquids such as LP gas.

- Integral construction includes both pump body and motor.

- The pump is UL approved for LP gas applications.
- Components under liquid pressure are made of ductile iron in conformance with UL51.
- Easily serviceable - impeller and mechanical seal can be accessed and replaced without disconnecting piping or motor.
- Inlet and outlet connections are 90 degrees apart and may be oriented in four different positions.
- 1/4" pressure gauge connections are located on the on the outlet nozzle.

Motor Features

- Listed by UL, file number E12044
- Explosion-proof, Class I Div 1, Group D
- Single phase. 60 Hertz, 115/230 volt
- Motor-mounted or wall-mounted manual starter standard.
- Conduit seal in the 3/4" NPT rigid galvanized steel nipple in conformance with NFPA 70-NEC, paragraphs 501.5.a.1 & 3.
- Motor Sealed at pipe nipple and filled with U.L. Approved Sealing Cement.

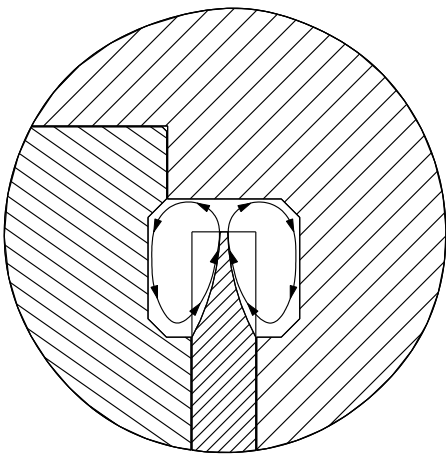

Figure 1a - Impeller vane cross-section

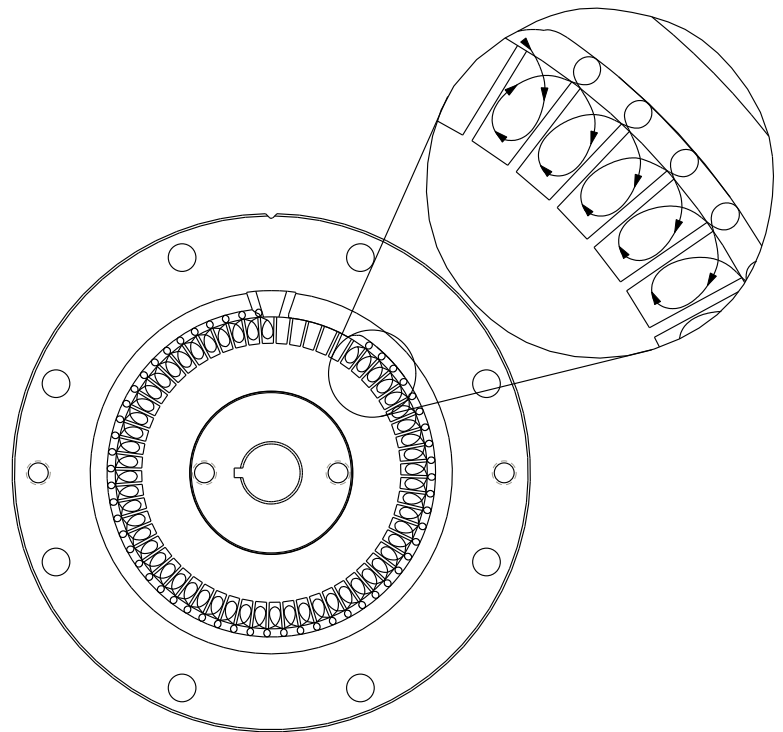

Figure 1b - Liquid flow through multiple vanes

Installing the PL100

Proper installation is critical when pumping volatile liquids. The following installation procedures have been thoroughly tested and should be followed as closely as possible to ensure peak performance and reliability. Specific installations may require slight variations in the piping design, but the fundamental principles must be observed.

If it is necessary to reorient the pump nozzles, the pump cover, impeller, and mechanical seal must be removed, followed by the four nuts securing the housing to the motor. The housing can then be pulled off the studs and reoriented. Reassemble in the reverse order.

It is critical that the pump not be allowed to run dry. Damage to the seal could be caused by product vaporization due to the inlet being restricted by an inadequate pipe size, restricted strainer, or improper location relative to the tank.

Locate the pump as close to the storage tank as possible. The total length of the inlet tubing, from the pump to the tank, must not exceed 12 feet.

Always locate the pump as low as possible below the level of the tank so that the product is gravity-fed to the pump location. (Liquefied gases can vaporize when drawn into a pump by suction.) The pump inlet should be at least 2 feet below the bottom of the tank, but 4 feet would be optimum.

Inlet Piping Requirements:

1. The tank excess flow valve should have a flow rate of 1.5 to 2 times the flow rate of the pump at operating conditions.
2. The tank shutoff valve should be an angle valve or a free flow type — not a standard globe valve.
3. A Y-type strainer with 1/16" mesh screen, must be used on the inlet line.
4. A section of flexible hose should be used at the inlet and outlet to eliminate strain from the fixed piping.
5. Unions must be installed near the pump inlet and outlet nozzles.
6. Inlet piping must be adequate to ensure a constant supply of liquid. Never use an inlet line of smaller diameter than the pump inlet. The same size line may be used for shorter runs, but for longer runs the line should be larger than the pump inlet.

7. Always use an eccentric reducer (not a concentric reducer) to reduce the inlet line size in the horizontal section of the inlet piping. The reducer should be installed flat side up to prevent vapor build-up.
8. The inlet line must be level or slope downward to the pump.

Outlet Piping Requirements:

1. A pressure gauge is critical for monitoring the pump's performance. Install the gauge in the opening on the outlet nozzle or in the outlet piping close to the pump.
2. A hydrostatic relief valve must be installed between any two valves that can be closed.
3. If the length of the outlet piping exceeds 50 feet, install a check valve near the pump outlet.
4. The outlet piping size is 1 inch length, and restrictions produce different pressure drop that effects flow rate.

Bypass System Requirements:

1. The pump bypass system is required to vent vapors and to act as a differential relief valve to insure proper pump operation.
2. The line must rise uninterrupted from the pump to the tank.
3. Always pipe the by-pass valve back to a port in the storage tank's vapor section, never back into the inlet piping of the pump.
4. Connect the bypass line using an excess flow valve or a vapor return valve (not a filler valve or back check valve) to allow for proper vapor return.
5. Avoid creating low spots in the by-pass line which can trap vapor and affect pump priming.

Motor Installation

The wiring of the electric motor is extremely important and must be done by a competent electrical contractor. The wire size chart indicates the minimum standards for wire sizes.

It is critical that the motor is wired for the available voltage level (115V or 230V). Connecting to the wrong voltage will severely damage the motor. Improper motor wiring will cause difficulties from low voltage. If you suspect you have low voltage, call your power company.

In explosion-proof motor applications in humid climates, the normal breathing and alternating temperatures of the motor (warm during operation and cold when stopped) will often cause moist air to be drawn into the motor housing. This moist air will condense and may eventually add enough free water

to the inside of the motor to cause it to fail. To prevent this, make a practice of running the motor and pump at least once a week on a bright, dry day for an hour or so (pump through the bypass system). During this time, the motor will heat up and vaporize the condensed moisture.

Power and input & output (I/O) wiring must be in accordance with Class I, Division 2 wiring methods, Article 501-4 (b), or the National Electrical Code, NFPA 70 for installations in the U.S., or as specified in Section 18-1J2 of the Canadian Electrical Code for installations within Canada, and in accordance with the authority having jurisdiction.

Wire Sizing Chart

Motor				(a) Recommended Wire Size, AWG		
Hp	Motor Phase	Volts	Approximate Full Load Amperes	Length of Run in Feet		
				0-100	to 200	to 300
1	1	115	16.0	8	6	4
		230	8.0	12	12	10
2	1	115	26.0	6	4	2
		230	13.0	10	8	6

(a) These are general guidelines. All installations must meet national and local electrical codes.

Operation

The following steps should be performed for the initial pumping operation:

1. Close shutoff valve on the end of the delivery hose.
2. Open the storage tank bottom shutoff valve.
3. Open the storage tank shutoff valve of the bypass system.
4. Check the motor for the proper voltage. (See instructions under driver installation.)
5. Start the pump and circulate liquid through the bypass system.
6. Adjust the bypass valve by turning the adjusting screw out until the pump pressure gauge shows nearly the same pressure it did before you started the pump. Screw the adjusting screw in until the pressure gauge indicates the pump is providing sufficient pressure to meet system differential pressure requirements (typically 50 to 60 psi above tank vapor pressure).

Filling New Cylinders and Tanks

All new containers must be purged of air before filling with LPG to ensure ease of filling and consistency of gas supply from the container.

Preventative Maintenance

Lubrication

This model is equipped with lifetime lubricated bearings.

Repair Service

After a long service life, repairs are limited to replacing the impeller or mechanical seal.

The only wearing part influencing the pumping action is the impeller, so we suggest the pump be given an "efficiency" test before any attempt is made to repair it. The trouble may lie in the piping system rather than in the pump. If the pump will still produce as much differential pressure when circulating through the bypass system as it did when new, you may be sure your problem is elsewhere. If the pump does not produce as much pressure as it did originally, remove the cover and inspect the impeller. If the Impeller is badly damaged, it must be replaced.

Impeller Replacement

Replacement is a matter of removing the cover and removing the old impeller from the shaft. If the old impeller is tight on the shaft, threaded bolt holes are provided in the impeller to use for pulling. The new impeller must be a good slip fit on the shaft; it should "float" on the shaft, so it may be necessary to sand the shaft lightly to get the proper fit.

Impeller and Seal Replacement

Seal replacement instructions begin on the next page. They can also be referenced in M-287-1

Extended Storage

1. Fill or thoroughly flush the pump with a light rust-inhibiting oil. (If the pump is flushed with oil, placing some desiccant packets inside the pump will provide added protection.)
2. Piping and tanks not in service should also be protected, as the rust that forms can destroy the pump's seals almost immediately after startup.
3. Plug all pump openings.
4. Store in a dry location.
5. Before placing the pump back into service, drain the oil and remove any desiccant packets.

Seal Replacement Instructions

Caution: Bleed all pressure from the pump and piping before replacing the seal assembly.

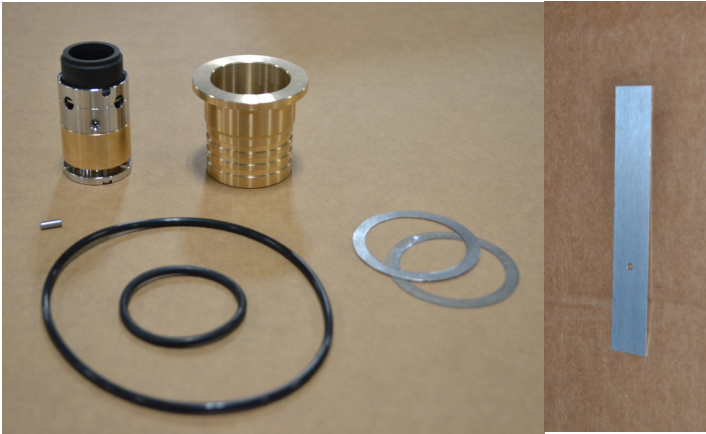

1. The kit includes the seal cartridge, seal housing, drive pin, housing o-ring, cover o-ring, housing shims (0.010" and 0.020"), and shim gauge.

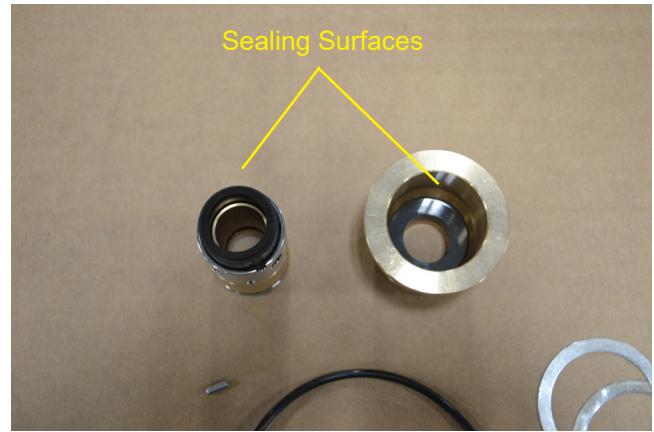

2. Do not touch the sealing surfaces on the seal cartridge or in the seal housing.

Remove the old seal, shims, and seal housing.

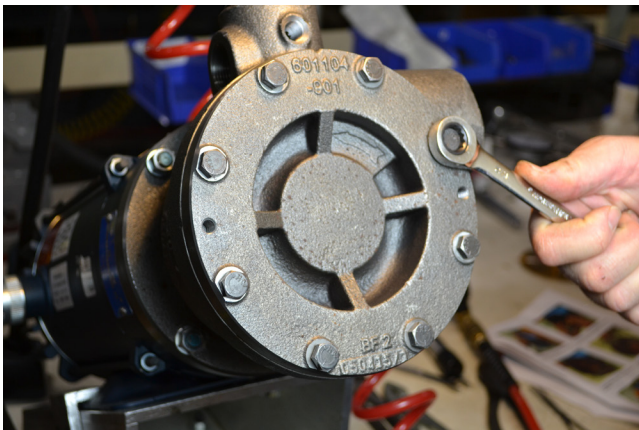

3. Remove the cover bolts and remove the cover from the case. **CAUTION: VENT THE PRESSURE FROM THE PUMP BEFORE LOOSENING THE COVER BOLTS.**

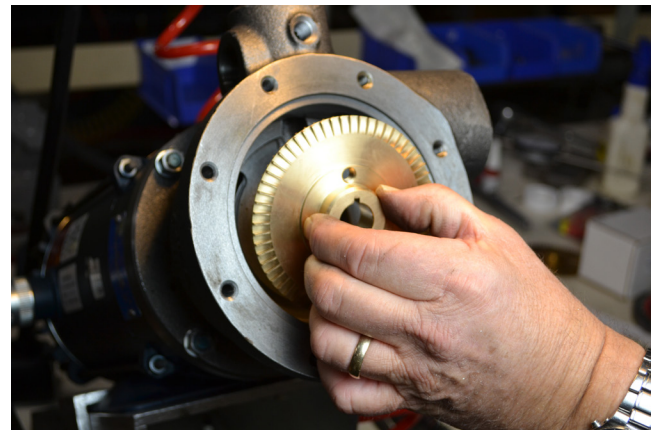

4. Remove the impeller. If it does not slide off freely, use two cover bolts in the threaded holes and pull off carefully. *If you are only replacing the impeller, proceed to Step 28.*

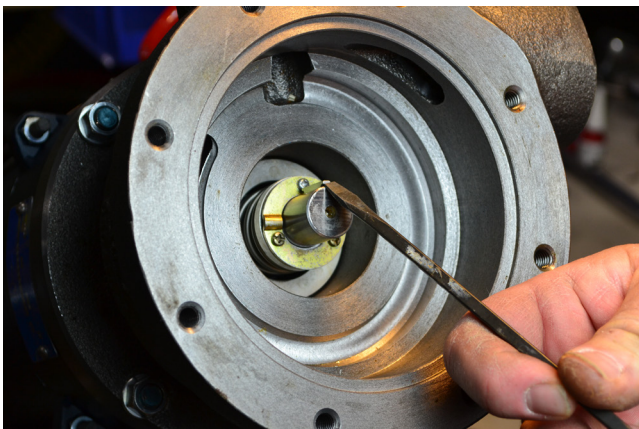

5. Carefully remove the impeller key, pushing the key up and out of its slot. Take care not to damage the shaft.

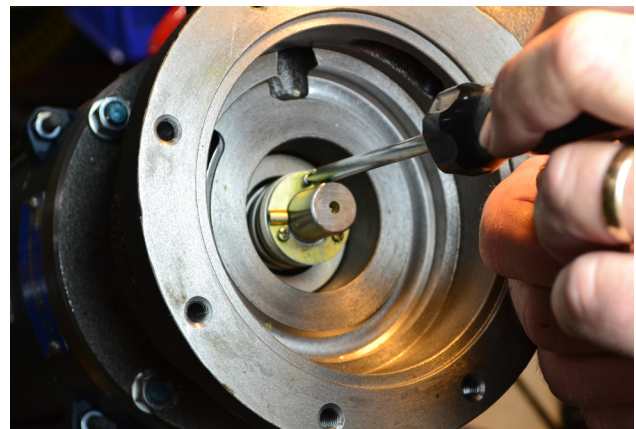

6. Remove the three screws from the seal clamp ring and remove the ring.

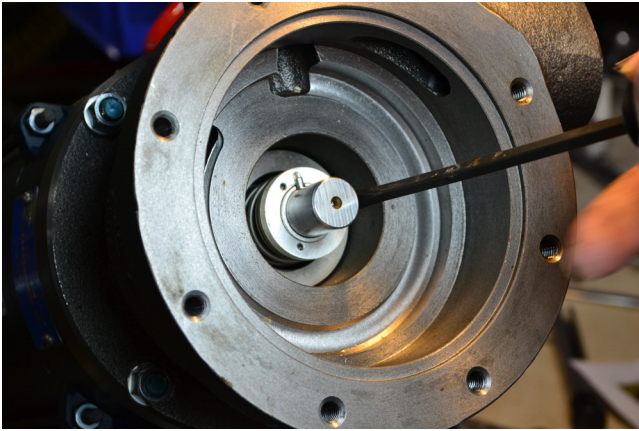

7. Press against the seal sleeve to provide clearance between the sleeve and the seal drive pin.

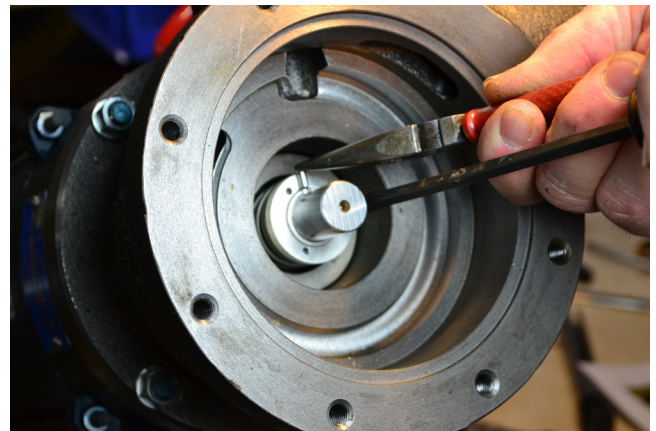

8. Remove the seal drive pin.

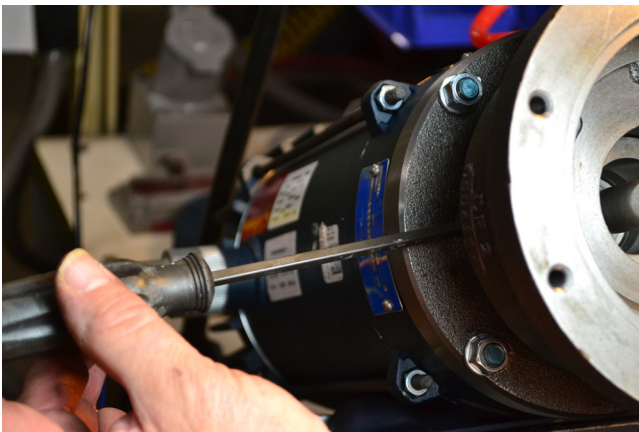

9. Through the exposed hole in the case, engage a screwdriver in the grooves on the seal housing and pry the housing and seal cartridge from the pump chamber.

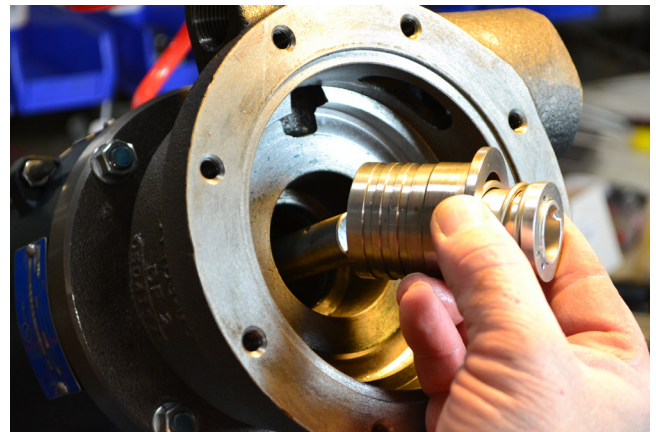

10. Remove the seal housing, seal cartridge, and any shims that were behind the seal housing.

Use the shim gauge to determine the correct thickness of shims to place under the lip of the seal housing.

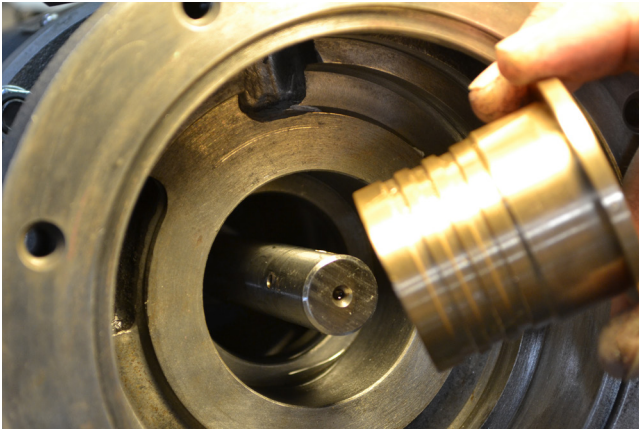

11. With no shims in place, install the new seal housing and press it in until fully seated.



12. If you have difficulty seating the housing, the old housing can be used to press it in place.

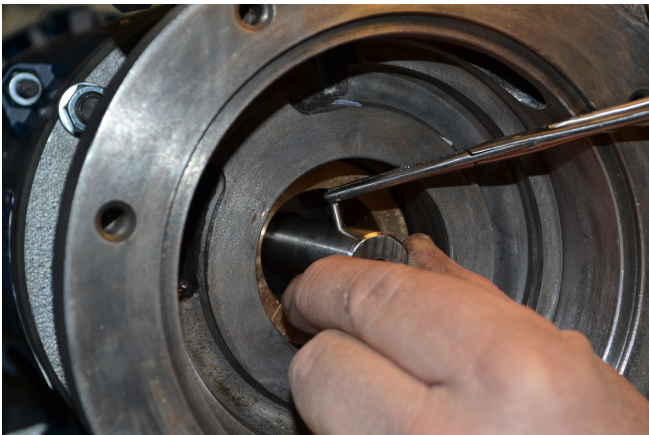

13. Temporarily install the drive pin into the hole in the shaft.



14. Place the shim gauge into the seal cup as shown, with the end of the gauge pressed flat against the base of the cup.

15. Attempt to align the hole in the gauge with the pin. If the hole does not line up with the pin, shimming is required. Repeat the preceding procedure with shims in place. When the proper shim thickness is achieved, the pin will drop into the hole in the shim gauge as shown in step 18. Two shims are provided with the seal, with thicknesses of .010" and .020". These can be used individually or together, allowing adjustment in increments of .010". If a greater thickness is necessary, the shim(s) that were removed from the original housing may also be used.



16. Correctly shimmed seal housing. At this point, remove the pin, shims, and seal housing before continuing.

Install the new housing and seal.

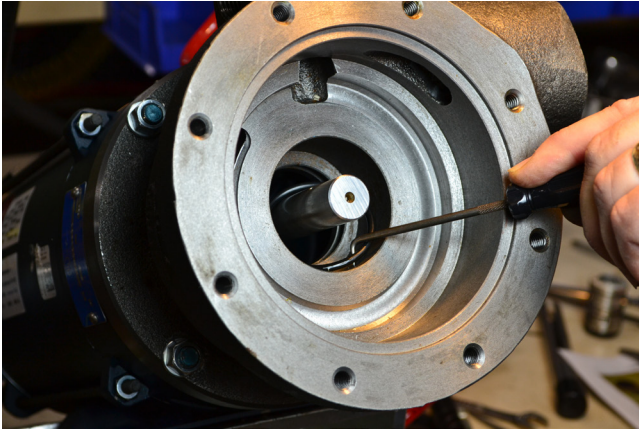

17. Remove the old seal housing o-ring from the groove in the pump body.

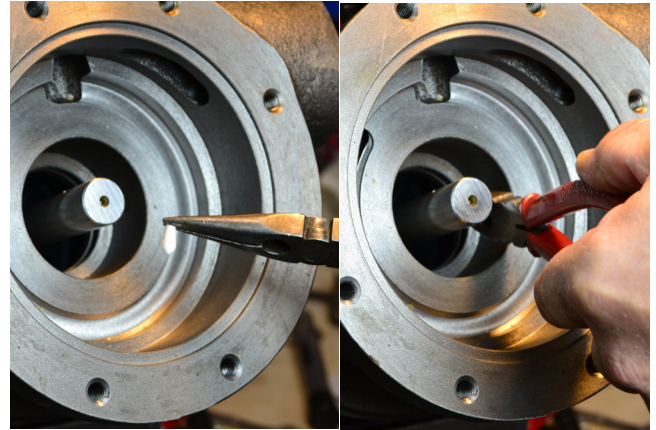

18. Clean the o-ring groove using an appropriate lint-free material. One method is to use the head of a cotton swab held with pliers. Clean the shaft and make sure it is free of burrs.

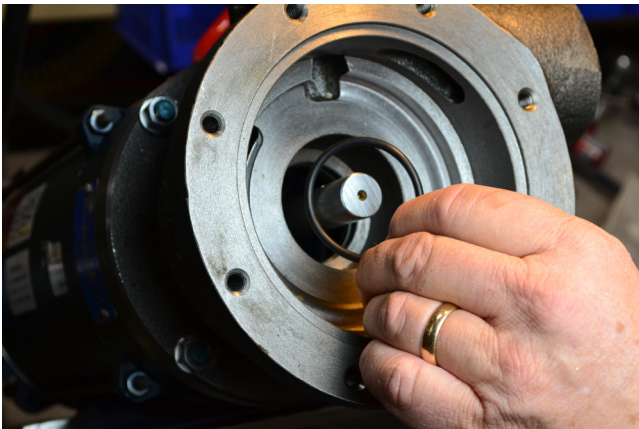

19. Apply oil to the new housing o-ring and install it in the pump body.



20. Place the shims over the housing. Note: during the following steps, be careful not to introduce foreign material or touch the seating surfaces. Rubber gloves are recommended.

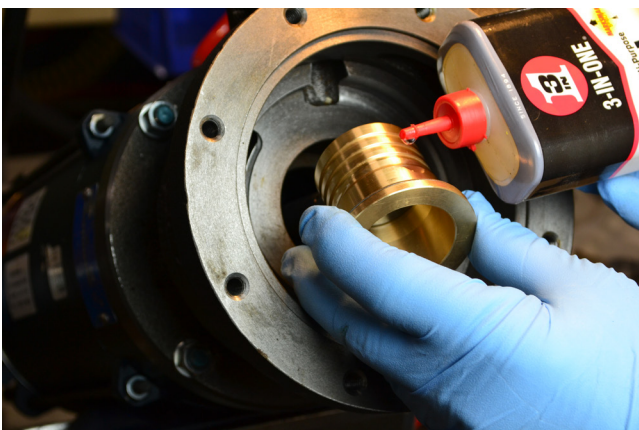

21. Apply a thin coat of light oil to the top ridge of the housing to facilitate installation into the o-ring.

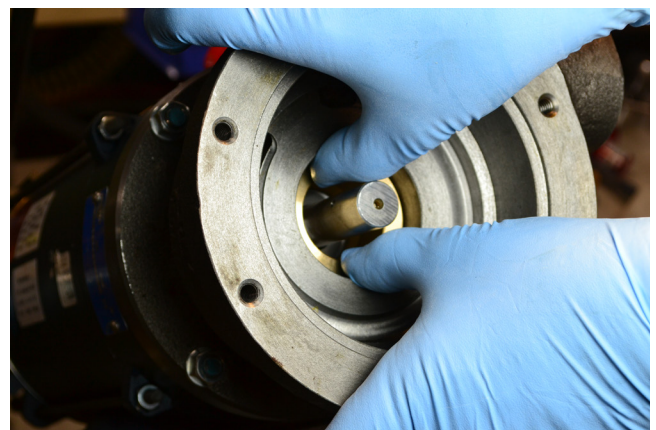

22. Install the new seal housing and press it in until fully seated.



23. If you have difficulty seating the housing, the old housing can be used to press it in place.

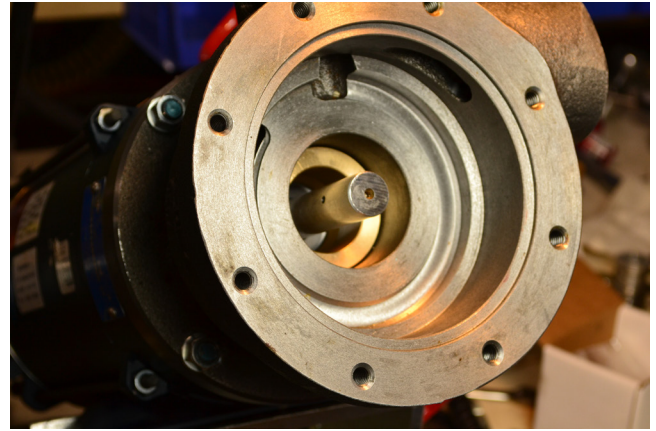

24. Properly installed housing.



25. Remove the seal ring from the new seal and set aside in a clean location.

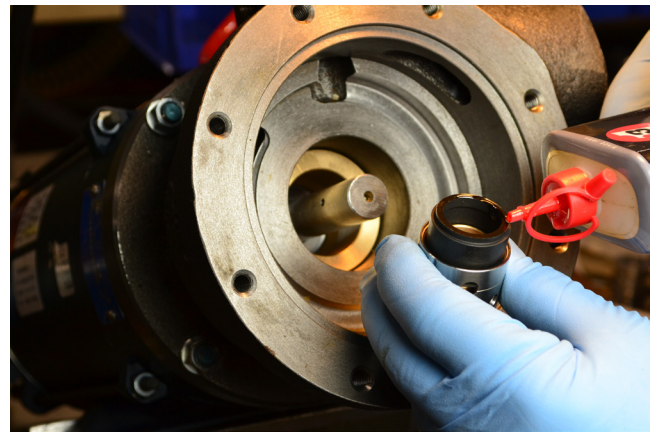

26. Apply a thin coat of light oil to the carbon surface of the seal.



27. Apply oil to the o-ring on the other end of the seal sleeve.



28. Install the new seal into the housing. Align the notch in the seal sleeve with the hole in the shaft.

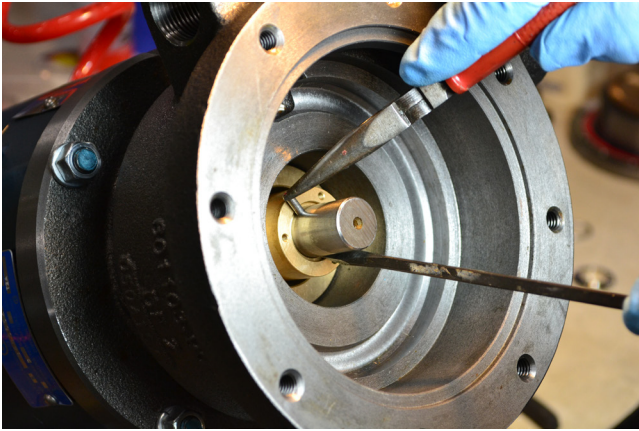

29. Push the seal sleeve back and install a new drive pin into the hole in the shaft. If there is not enough clearance to install the pin, remove shim(s) from the housing.

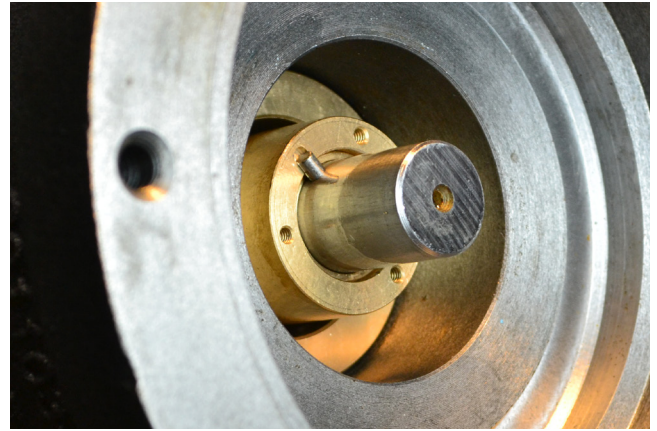

30. Seal and pin installed.

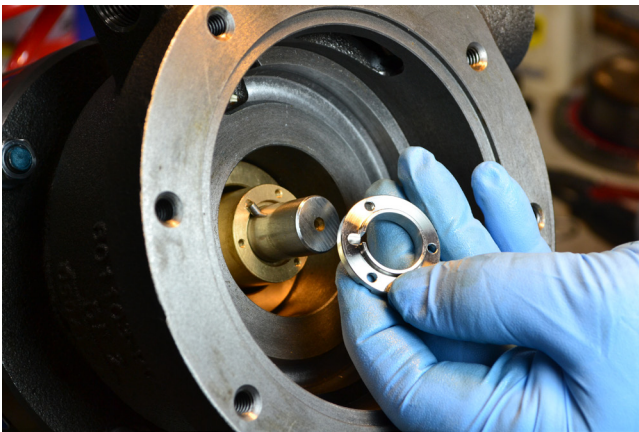

31. Install the seal clamp ring that was previously removed from the new seal cartridge. Align the notch in the ring with the drive pin.

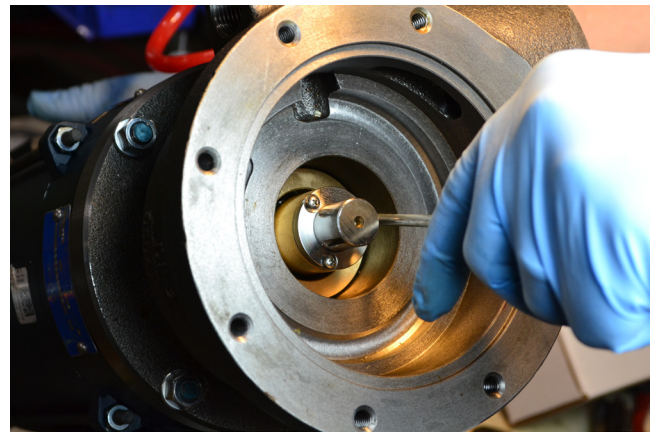

32. Install the seal clamp ring screws and tighten

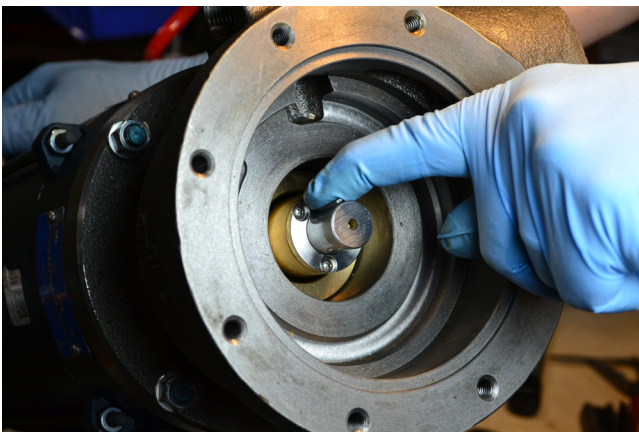

33. Make sure there are no burrs on the impeller key and install it into the keyway slot. The impeller must slide over the shaft and key freely.



34. Shaft key properly installed. *If you are replacing the impeller only and have not removed the key, verify that it is still seated correctly and the key and shaft are free of burrs and foreign material.*

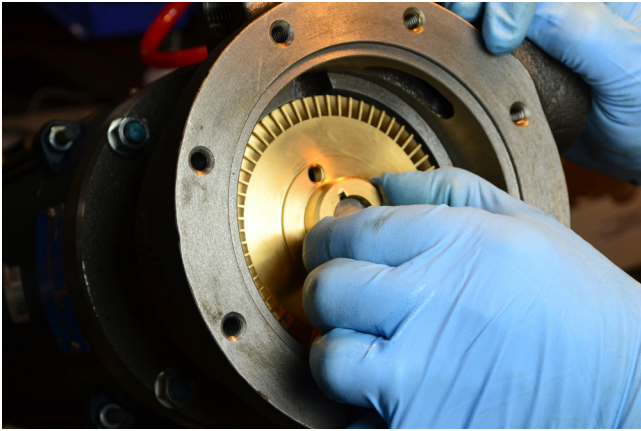

35. Replace the impeller, making sure that it slides freely over the shaft and key.

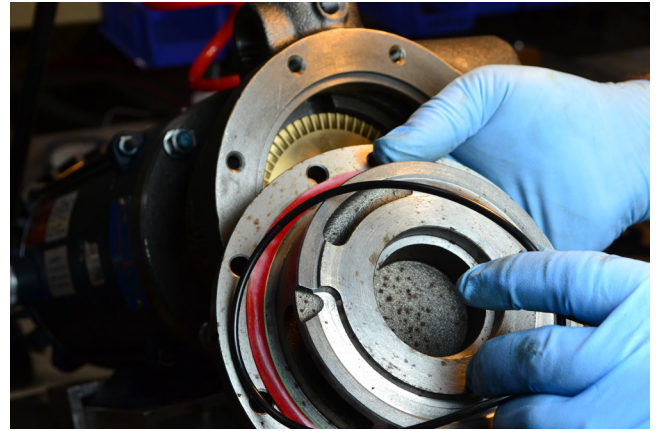

36. Remove the old cover o-ring. Make sure the cover surface is clean and install the new o-ring. If cover shims were used, put them back in place if they were removed during disassembly.

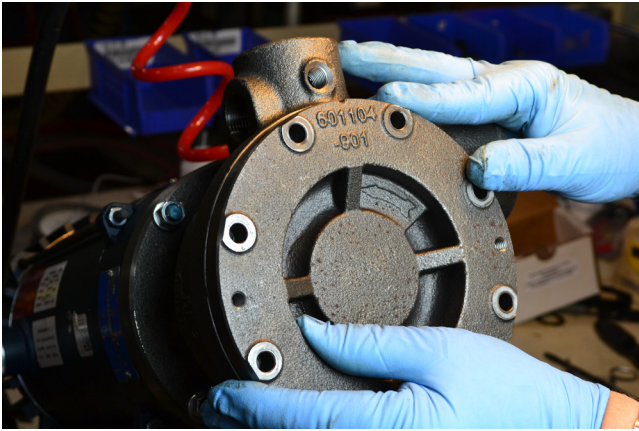

37. Replace the pump cover.

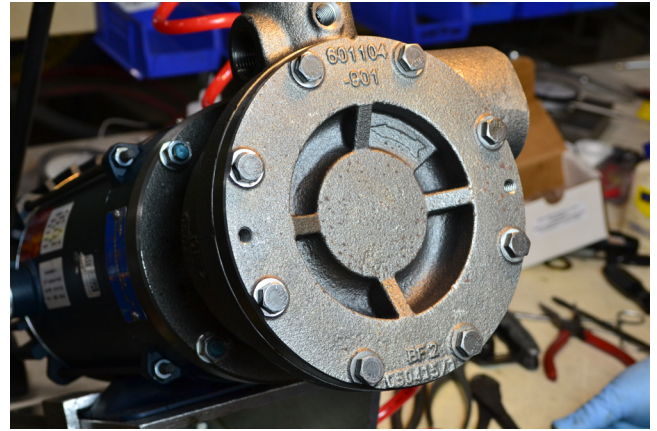

38. Reinstall the cover bolts.

Parts Detail

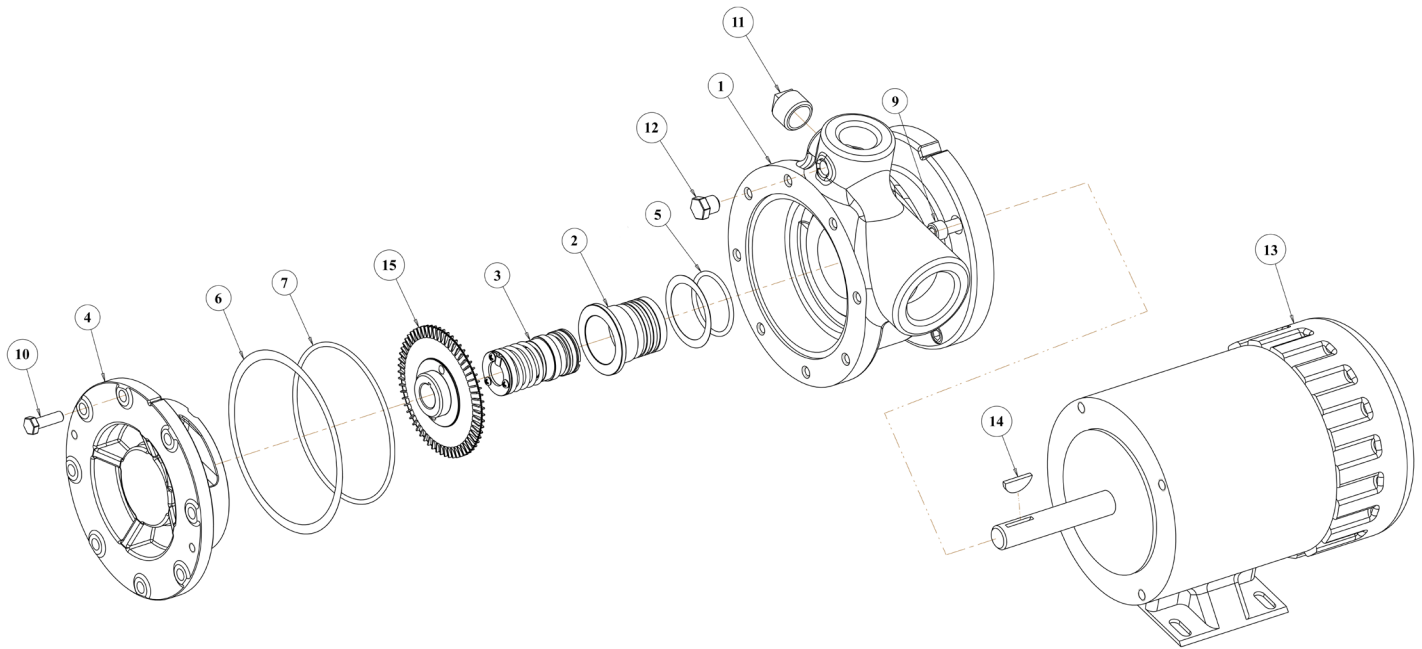

Ref. No.	Part No.	Description	Qty. 1 HP	Qty. 2 HP
1	601103-001	Pump maincase	1	1
3*	601508-000	Seal	1	1
4	601104-001	Cover	1	1
5*	601170-001	Housing O-ring	1	1
6*	601130-001 601130-002	Case clearance shim	As req.	As req.
7*	100139-022	Case O-ring	1	1
9	008325-014	SCR 3/8-16 X I S.H.C.S.	1	1
10	601172-001	Hex head cap screw	8	8
11	601173-001	Pipe plug, 3/4" NPT	1	1
12	601174-001	Pipe plug, 1/4" NPT	1	1
13A	601174-001	Motor 1 hp	1	
14	601176-001	Woodruff key	1	1
15	601105-001	Impeller	1	1
13B	601174-002	Motor 2 HP		1

*Seal Replacement Kit, 601341-000

contains the following components:

601508-000 Seal

100139-022 Case O-ring

601130-001 .010" Shim

601130-002 .020" Shim

601170-001 Housing O-ring

Construction

Part	Material, Standard
Case, cover	Ductile iron ASTM A536
Impeller	Bronze
Impeller key	Steel
Seal seat	Steel
seal rotor	Carbon
Seal metal parts	Steel
Seal sleeve	Aluminum
Seal follower	Aluminum
Seal housing	Steel
O-rings	Buna-N
Bearings	Steel

PL100 Specifications

Motor Rating	1 HP	2 HP
Inlet Connection	1 1/2" NPT	1 1/2" NPT
Outlet Connection	1" NPT	1" NPT
RPM	3540 @60 Hz	3560 @60 Hz
Max. Differential Pressure	100 psig (6.9 bar)	125 psig (8.6 bar)
Max. Working Pressure	350 psig (27.6 bar)	350 psig (27.6 bar)
Temperature Range	-25°F to 225°F (-32 C to 107 C)	-25°F to 225°F (-32 C to 107 C)
Capacities	15.8 gpm (59.8 lpm) @ 20 psid (1.4 bar) 9.2 gpm (34.8 lpm) @ 70 psid (4.8 bar) 5.2 gpm (19.7 lpm) @ 100 psid (6.9 bar)	16.6 gpm (62.8 lpm) @ 20 psid (1.4 bar) 10.8 gpm (40.9 lpm) @ 70 psid (4.8 bar) 4.7 gpm (17.8 lpm) @ 125 psid (8.6 bar)
Performance at 60 Hz (1)		
Fill 20# Cylinders	20 to 35 seconds	15 to 30 seconds
Fill 100# Cylinders	3 to 4 minutes	2 to 2 1/2 minutes
Motor Fueling	12 gpm	14.5 gpm
Weight:	67 lbs	72 lbs

1. Estimated performance - actual performance may vary due to system design and other variables.

Dimensions

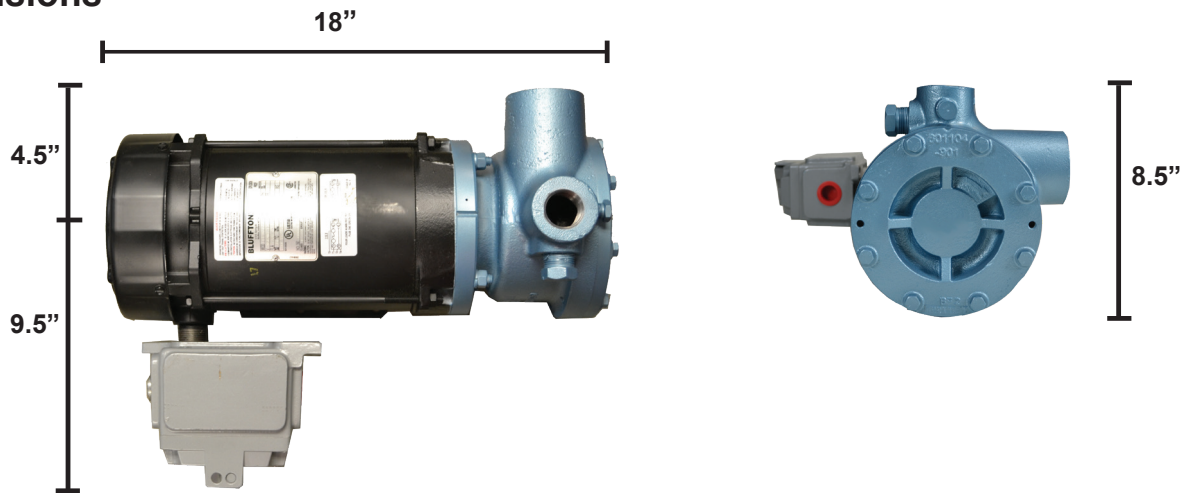

Troubleshooting Guide

Problem	Possible Causes	Solution
Low Capacity	Pump speed too low	Check the RPM of the electric motor
	High differential pressure	Check for restrictions or undersized discharge piping
	Vapor lock	See above for high differential pressure
	By-pass valve stuck open or set too low	Readjust, repair or replace the by-pass valve
	Clogged strainer	Clean strainer screen
	Worn impeller	Replace the impeller
	Suction pipe too small or restricted (inlet pressure drops on start-up)	Clear restrictions or increase size
Pump runs but no flow	Valve closed	Open valve
	Excess flow valve slugged or closed	Stop pump until the valve opens
	Wrong rotation	Check the rotation of the electric motor and change the rotation
	Suction pipe too small or restricted (inlet pressure drops on start-up)	Clear restrictions or increase size
Pump will not turn -- locked	Foreign material in the pump	Clean out the pump — inspect the strainer screen
	Bearing seized	Replace the motor bearings.
	Frozen Moisture in the pump	Thaw and break loose carefully. Properly remove the moisture from the product.
Pump will not build pressure	Poor suction conditions	Check the storage tank excess flow valve— clean filter screen. The suction pipe might be too small or restricted.
	By-pass valve set too low	Set the valve for higher pressure (see valve's instructions).
	Too much impeller clearance	Do a performance test on the pump
Noise or vibration in the pump	Worn bearings	Replace
	Defective or wrong size bypass valve	Repair or replace the valve.
	Loose anchor bolts	Tighten all bolts
Electric motor gets hot or overload protection kicks out	High differential pressure	Check the motor's full load amperage. Adjust the by-pass valve setting to a lower setting.
	Low line voltage	Check line voltage when in operation. Be sure motor is wired for the proper voltage.
	Motor shorted	To eliminate possible shorts from moisture condensation, operate the motor at least once a week until it's hot enough to evaporate the moisture.
Leaks	Failed O-rings or mechanical seal assembly	Inspect and replace the seals and O-rings, if needed.