



# PL100

## LPG Dispenser Pump

- Designed for LPG dispensers
- Highly efficient regenerative turbine technology
- Integral pump/motor construction
- Compact design
- Ductile iron components
- Remote-mountable switch enclosure
- Inlet/outlet configuration can be repositioned in 90° increments
- Service without disconnecting piping
- Easy seal and impeller replacement
- UL Listed Class 1 Div 1 Group D



Combine the PL100 pump with the Neptune 4D-MD meter for a complete LPG dispenser solution!



Optional bypass valve improves performance by eliminating vapor and maintaining prime.

# PL100 Operating Specifications

Motor Rating	1 HP	2 HP
Inlet Connection	1½" NPT	1½" NPT
Outlet Connection	1" NPT	1" NPT
RPM	3540 @60 Hz	3560 @60 Hz
Max. Differential Pressure	100 psig (6.9 bar)	125 psig (8.6 bar)
Max. Working Pressure	350 psig (27.6 bar)	350 psig (27.6 bar)
Temperature Range	-25°F to 225°F (-32 C to 107 C)	-25°F to 225°F (-32 C to 107 C)
Capacities	15.8 gpm (59.8 lpm) @ 20 psid (1.4 bar) 9.2 gpm (34.8 lpm) @ 70 psid (4.8 bar) 5.2 gpm (19.7 lpm) @ 100 psid (6.9 bar)	16.6 gpm (62.8 lpm) @ 20 psid (1.4 bar) 10.8 gpm (40.9 lpm) @ 70 psid (4.8 bar) 4.7 gpm (17.8 lpm) @ 125 psid (8.6 bar)
Performance at 60 Hz (1)		
Fill 20# Cylinders	20 to 35 seconds	15 to 30 seconds
Fill 100# Cylinders	3 to 4 minutes	2 to 2½ minutes
Motor Fueling	12 gpm	14.5 gpm
Weight:	67 lbs	72 lbs

(1) Estimated performance - actual performance may vary due to system design and other variables.

## Dimensions

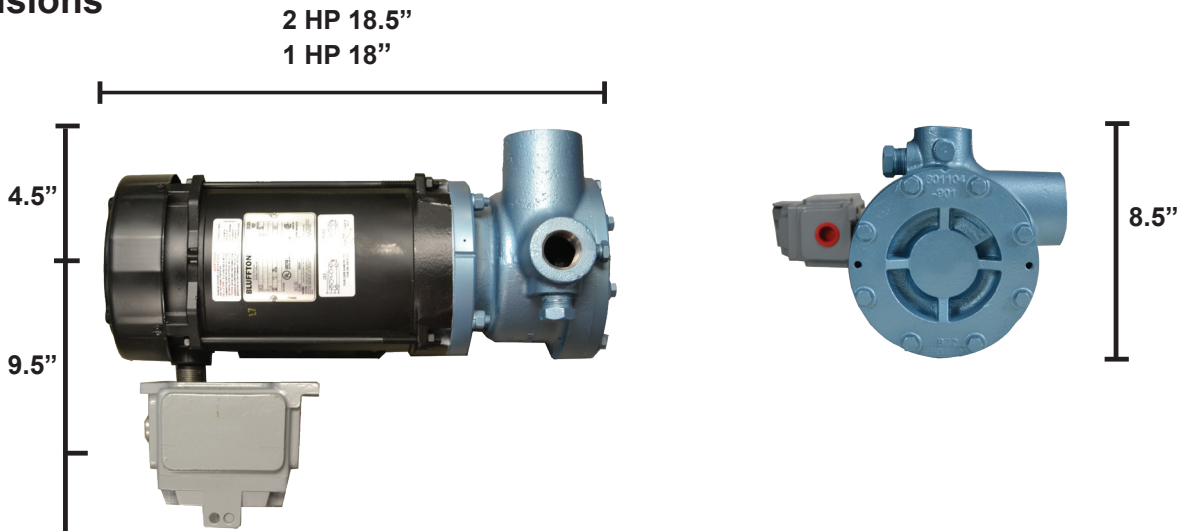

## Operating Principle

In a regenerative turbine pump, liquid is drawn into the inlet and enters a chamber where it flows around a double-sided impeller. The liquid entering the pump is directed into the vanes, which move the liquid forward while at the same time imparting a circulatory motion within the vane, increasing the liquid's kinetic energy. As the liquid leaves one vane, it is directed into the next, and the process is repeated. Each successive trip through the vanes results in further gain of energy. This process is called regeneration, and enables the pump to deliver an outlet pressure up to ten times greater than a centrifugal pump with the same impeller diameter.

Since the impeller is the only moving part and has no contact with the casing, it experiences practically no wear, even when pumping volatile, non-lubricating liquids such as LP gas.

