



MODEL 300 EXTERNAL CALIBRATOR

- One Adjustment Dial
- Adjustment Range $\pm 7\%$
- Eliminates Changing Gears
- Positive Gearing Eliminates Slippage
- Easy Installation
- Sealable By Weights & Measures

DESCRIPTION

The Red Seal External Calibrator is a variable ratio changing device. It is located between the flowmeter and Model 800 Series Register. The calibrator mechanism is enclosed in a sturdy aluminum housing and can be installed on any Red Seal flowmeter which uses an 800 Series Register. It is ideal for Tank Truck Service Dispensing Systems used for custody transfer, which may require periodic calibration of the flowmeter.

DESIGN FEATURES

The Model 300 External Calibrator also serves industrial applications requiring fine tuning for increased accuracy requirements. The model 300 may be used in meter applications where fluids of different viscosities are being measured through one meter.

The external calibrator eliminates the need for changing gears because the ratios available from Red Seal change gear combinations can be duplicated with the calibrator by simply adjusting the dial.

The calibrator permits flowmeter calibration in graduations of 0.1% and has a $\pm 7\%$ range. Corrections are made by using a screwdriver to remove the coverplate and adjusting one dial. Additionally, the entire calibrator unit and its adjustments can be sealed by a weights and measures inspector.



The unique design utilizes positive gearing throughout to eliminate slippage inherent in friction drive devices. The external calibrator's variable ratio drive unit mechanism is identical to the mechanism used in the Automatic Temperature Compensator, a dependable product which has been the standard of the industry for more than 30 years.



**2" Type MP with Model 300
Calibrator and 800 Series Register**

DIMENSIONAL DATA

mm (in)

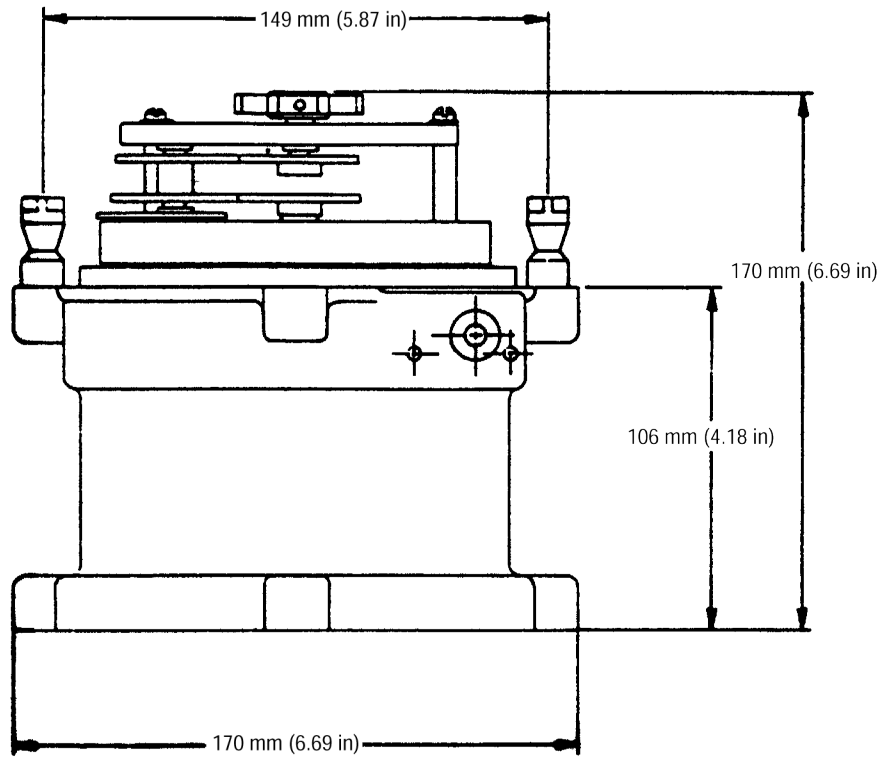

1310 Emerald Road
Greenwood, SC 29646
USA
Phone: 1.800.833.3357
Fax: 1.864.223.0341

